

Vitotwin 350-F and 300-W micro CHP units: The boilers that generate power

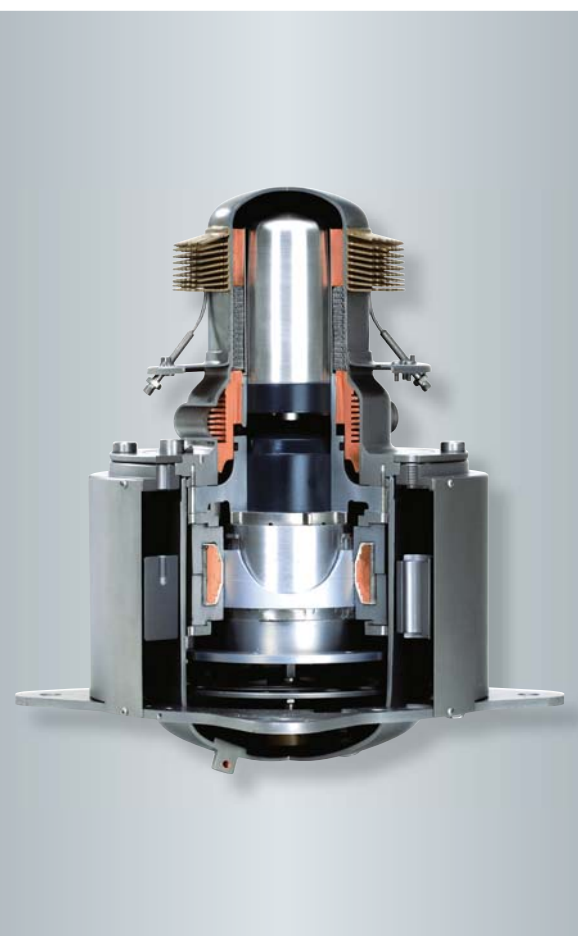

По вопросам продаж и поддержки обращайтесь:

Архангельск (8182)63-90-72
Астана +7(7172)727-132
Астрахань (8512)99-46-04
Барнаул (3852)73-04-60
Белгород (4722)40-23-64
Брянск (4832)59-03-52
Владивосток (423)249-28-31
Волгоград (844)278-03-48
Вологда (8172)26-41-59
Воронеж (473)204-51-73
Екатеринбург (343)384-55-89
Иваново (4932)77-34-06
Ижевск (3412)26-03-58
Иркутск (395) 279-98-46

Казань (843)206-01-48
Калининград (4012)72-03-81
Калуга (4842)92-23-67
Кемерово (3842)65-04-62
Киров (8332)68-02-04
Краснодар (861)203-40-90
Красноярск (391)204-63-61
Курск (4712)77-13-04
Липецк (4742)52-20-81
Магнитогорск (3519)55-03-13
Москва (495)268-04-70
Мурманск (8152)59-64-93
Набережные Челны (8552)20-53-41
Нижний Новгород (831)429-08-12

Новокузнецк (3843)20-46-81
Новосибирск (383)227-86-73
Омск (3812)21-46-40
Орел (4862)44-53-42
Оренбург (3532)37-68-04
Пенза (8412)22-31-16
Пермь (342)205-81-47
Ростов-на-Дону (863)308-18-15
Рязань (4912)46-61-64
Самара (846)206-03-16
Санкт-Петербург (812)309-46-40
Саратов (845)249-38-78
Севастополь (8692)22-31-93
Симферополь (3652)67-13-56

Смоленск (4812)29-41-54
Сочи (862)225-72-31
Ставрополь (8652)20-65-13
Сургут (3462)77-98-35
Тверь (4822)63-31-35
Томск (3822)98-41-53
Тула (4872)74-02-29
Тюмень (3452)66-21-18
Ульяновск (8422)24-23-59
Уфа (347)229-48-12
Хабаровск (4212)92-98-04
Челябинск (351)202-03-61
Череповец (8202)49-02-64
Ярославль (4852)69-52-93

Киргизия (996)312-96-26-47

Казахстан (772)734-952-31

Таджикистан (992)427-82-92-69

Эл. почта: vnt@nt-rt.ru || Сайт: <http://vito.nt-rt.ru/>



Vitotwin 350-F and Vitotwin 300-W micro CHP units: Generate power while you heat

Achieve greater independence from ever rising electricity prices. The Vitotwin 350-F and Vitotwin 300-W micro CHP units generate power while providing heat.

Energy prices have more than doubled over the past ten years, and it is highly unlikely that they will fall in the future. Quite the contrary, as resources become more scarce, it is expected that energy costs will continue to rise. This brochure contains information about an innovative way to generate power that can help you to become more independent of these rising prices. It describes a heating system that generates heat and power simultaneously – the combined heat and power boiler for detached and two-family houses.

Vitotwin 350-F and Vitotwin 300-W – specifically designed to meet modernisation requirements

Combined heat and power (CHP) units are a genuine alternative to conventional heating systems when modernising.

While gas boilers generate only heat, a micro CHP unit simultaneously generates heat and power for on-site consumption. Any excess power not used on site is exported to the public grid and reimbursed. The integral Stirling engine is sized to cover the base load of power and heat in detached and two-family houses. At times of higher heat demand, the gas condensing boiler covers the shortfall.

As the CHP unit constantly generates heat during operation, a heating water buffer cylinder is required. With the Vitotwin 350-F this is already integrated. The size of the DHW cylinder can be matched to the respective demand. However, in order to qualify for a BAFA subsidy, the cylinder capacity must be in excess of 200 litres.

The use of combined heat and power generation makes users less dependent on external power supply utilities and provides protection against rising electricity prices.

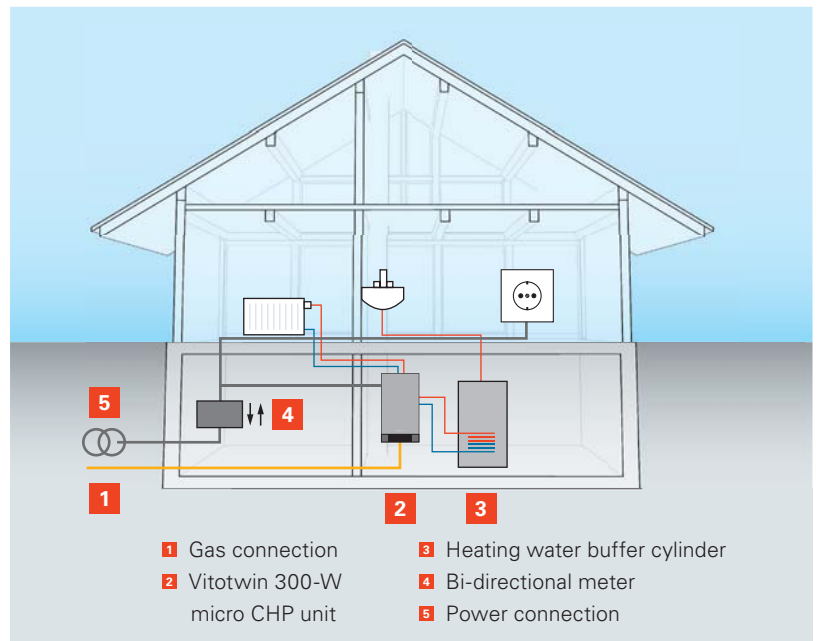

CHP benefits at a glance

- Greater independence from energy supply utilities
- Minimised domestic electricity bills thanks to on-site consumption of home-generated power
- Convenient and ecologically sound heat generation
- Compact dimensions and easy to service
- Public subsidy for investment and for generated power

Generating power while you heat could not be more simple

It certainly pays if you generate your own power while you heat. The principle is simpler than you'd have thought.

Normally, you buy electricity and use it to generate heat in your boiler. But why not generate both yourself, with a heating system that delivers heat and power?

Have your own power station at home

During conventional power generation in central power stations, heat is created and is then simply lost as waste heat. Only around 38 percent of the latent energy in fuel is converted into power and sold to you. To put it simply, you pay for the full 100 percent, but you can use only 38 percent.

It is precisely here that the CHP principle plays its trump card. The micro CHP unit is like a decentralised power station, which generates power and heat immediately where and when required – in your home.

Depending on demand, up to 100 percent of the power created during heat generation can be utilised on site.

Simple yet extremely effective:

The technical principle

In the Vitotwin 350-F and Vitotwin 300-W micro CHP units, heat is generated by means of a Stirling engine. This is driven by a gas burner. Power is generated – almost as a by-product – whilst heat is being produced. The heat generated is sufficient for most times of year. On the rare occasions when additional heat is required, the peak load boiler starts up. This takes the form of a gas condensing boiler that has been integrated into the appliance.

The micro CHP unit saves money – and "earns its keep" as well

Utilising waste heat from power generation can save up to 29 percent primary energy. And since CO₂ emissions are also drastically reduced, you are making an important contribution to climate protection when you choose a micro CHP unit. In return, local and regional governments will reward you with subsidies [local terms may vary].

Stirling engine

- 1 Stirling head
- 2 Heat exchanger fins
- 3 Regenerator
- 4 Displacement piston
- 5 Water-cooled area
- 6 Main piston
- 7 Magnetic mantle
- 8 Copper coil

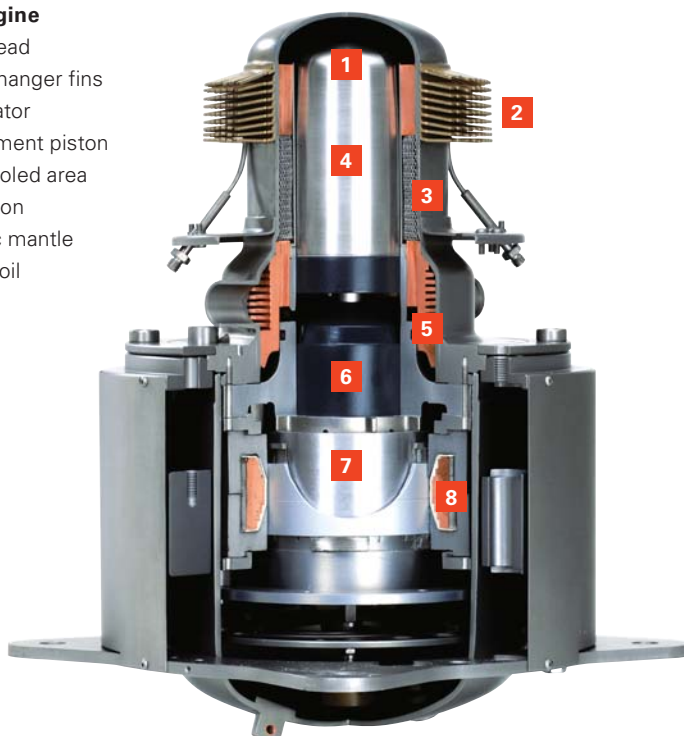

Quiet running and maintenance-free Stirling engine

The Stirling engine is hermetically sealed, quiet and maintenance free. These features enable it to be installed near the living space.

Two pistons work inside the Stirling engine, the movement of which is converted into electrical power. The waste heat generated by this process is available for heating purposes. An overall efficiency [to DIN] of 96 percent (Hs [gross cv]) demonstrates the energy utilisation of the Stirling engine as being highly effective.

The micro CHP appliance operates with exceptional economy where the annual gas consumption is at least 20,000 kWh and the power consumption exceeds 3000 kWh per annum. This is exactly the demand of an average modernised detached or two-family house.

Power generation at home at the press of a button

The Stirling engine can be individually started by means of a time switch, by pushbutton on a remote control or via the new wireless sockets. This enables a targeted on-site power supply when there is a high demand, such as when washing or cooking. The power generated by the Stirling engine no longer needs to be bought in, which reduces the electricity bills.

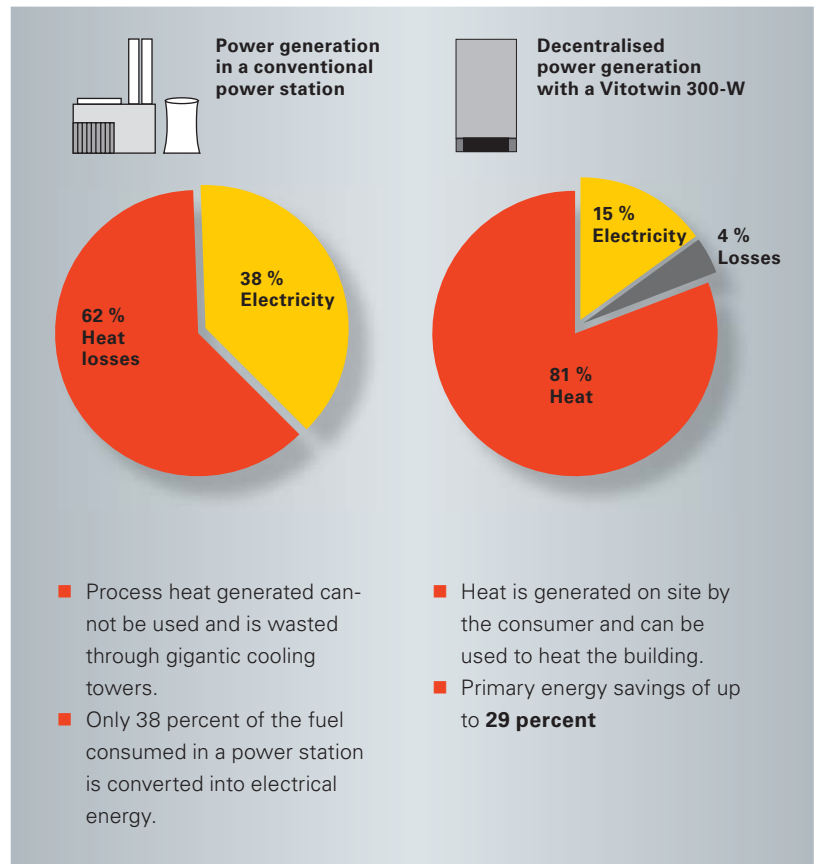

Modernisation with micro CHP unit*

	Savings in consumption p.a.	Monetary savings p.a.	Total savings
	Gas: 380 m³	Gas: €270	€1430 39 %
	Power: 3700 kWh	Power: €890	

* Basis for comparison: House (built 1980), 140 m² living space with old 27 kW gas boiler. Rounded consumption costs applying standard values (EID) for 3400 m³ natural gas. Average energy prices 2011. On-site power consumption > 80 %

Heating system		Old system	Micro CHP unit
Consumption/year	(gas)	3400 m ³	3020 m ³
	(power)	5000 kWh	1300 kWh
Costs/year	(gas)	€2510	€2240
	(power)	€1200	€310
Subsidy for power generation			€270

VITOTWIN 350-F VITOTWIN 300-W

10-year guarantee

on stainless steel heat exchangers for
oil or gas condensing boilers up to 150 kW

For conditions and product overview,
see www.viessmann.de/garantie

Power and heat for private dwellings – the Vitotwin is perfectly tailored to the modernisation of heating systems in detached and two-family houses.

Compact, convenient, powerful – Vitotwin 350-F and Vitotwin 300-W are genuine alternatives to conventional heating systems when modernising. The micro CHP unit delivers cosy warmth to your home all year round and is ideal for covering the electricity base load.

Low installation effort, with Stirling engine and gas condensing boiler housed in a single appliance

Where others have to deploy two appliances, Viessmann offers you a single compact system that combines all components of a micro CHP unit. In addition to the Stirling engine, a gas condensing boiler has been integrated as a peak load boiler. The Vitotwin 350-F also houses a heating water buffer cylinder inside its casing. The result speaks for itself: Combining fully developed technologies ensures the highest possible reliability. The Stirling engine and condensing boiler are perfectly matched. In addition, the Vitotwin requires just one gas supply and one flue.

Quick installation and service

Installing the Vitotwin could not be easier. As the Stirling engine and peak load boiler are united in a single appliance, they can share the connections and flue system. All that the power supply utility needs to do is replace the old meter with a bi-directional meter [where applicable]. The power generation meter is already integrated in the Vitotwin.

Maintenance-free Stirling engine

Servicing is even easier: The Stirling engine is completely maintenance-free, so only the gas condensing boiler and the ring burner of the Stirling engine require the usual servicing.

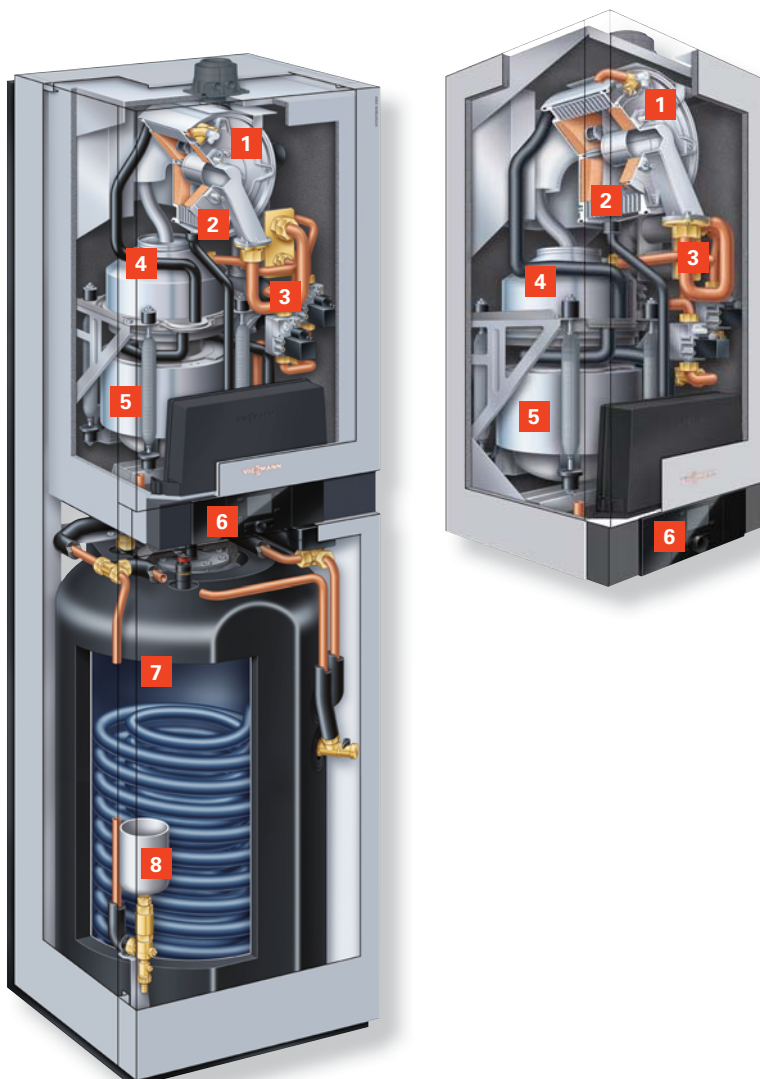

Vitotwin 350-F Vitotwin 300-W

- 1 Peak load boiler
- 2 Stainless steel Inox-Radial heat exchanger
- 3 Air distribution valve
- 4 Ring burner
- 5 Stirling engine
- 6 Control unit
- 7 Heating water buffer cylinder with system separation (175 l capacity)
- 8 Expansion vessel



Vitotwin 350-F compact micro CHP unit with adjacent Vitocell 300-W DHW cylinder



Vitotwin 350-F compact micro CHP unit

Take advantage of these benefits:

- Ideal for modernising detached and two-family houses
- Parallel generation of heat and power
- Stirling engine: 0.6 bis 1 kW kW_{el} , 3.6 to 5.3 kW_{th}
Overall efficiency [to DIN]: 96 % (H_g) [gross cv] / 107 % (H_f) [net cv]
- Appliance as a whole: 3.6 to 26 kW, efficiency [to DIN]: 98 % (H_s) [gross cv] / 109 % (H_f) [net cv]
- Reduced dependency on steeply rising electricity prices due to on-site generation and use of power
- Automatically regulated power generation via wireless sockets: washing machine, dryer, etc. send an automatic starting signal to the Stirling engine
- The Stirling engine can operate for up to two hours with power bias
- Integral heat meter reduces installation costs and enables BAFA subsidies (€2375) [local terms may vary]
- Patented process for capturing the amount of gas for the Stirling engine enables tax rebates; a second meter is not required (savings of around €300)
- Diverse operating options via wireless remote control (standard delivery), Vitodata or app
- Very quiet operation
- Straightforward installation (similar to that of a gas condensing boiler)

Vitotwin 350-F

- Compact micro CHP unit with integral 175 l heating water buffer cylinder and system separation
- Reduced operating noise resulting from additional sound insulation and anti-vibration measures between unit and wall
- Fully pre-fitted sensor and hydraulic equipment

* Electrical output with reference to the conditions of EN 50465. Different conditions can result in an increased or reduced output.

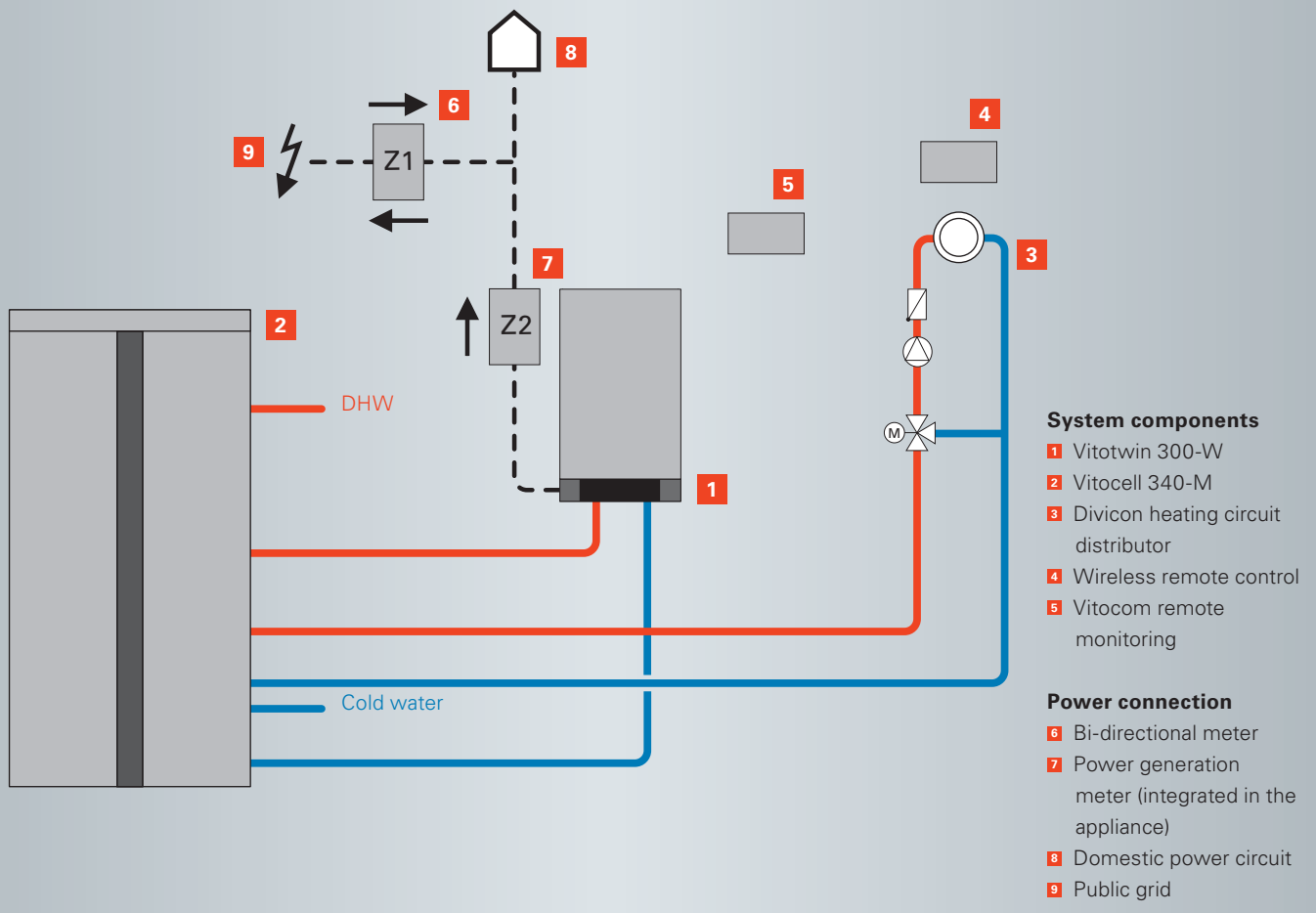

Vitotwin 300-W as part of a system:
All components are matched to ensure the highest efficiency of the overall system.

Efficient by design

The comprehensive range from Viessmann offers the complete spectrum of system components for the Vitotwin 350-F and Vitotwin 300-W from a single source. As a result, you can be sure that all components are a perfect match.

All heating systems are made up of different components – the same goes for micro CHP units. However, it is not enough that the individual components used are well made. Their optimum interaction is of equal importance. You can rely on that with Viessmann.

Thanks to the comprehensive range from Viessmann, you can obtain all system components from a single source. As they are perfectly matched, you can count on these components to deliver highest efficiency and reliability, as well as a long service life.

Viessmann combi cylinder – perfectly sized for use with the Vitotwin 300-W

Viessmann system solutions enable you to make optimum use of the energy from your micro CHP unit, with the Vitocell 340-M combi cylinder, for example. Longer running times enable the Stirling engine to generate heat continuously. The Vitocell 340-M stores the heat that is not needed at the time. This ensures long runtimes and reduced cycling of the Stirling engine – which means maximum DHW convenience for you. With a cylinder capacity of 950 litres, the Vitocell 340-M meets even the highest demands.

Stainless steel for the most stringent hygiene standards

With its internal indirect coil made from stainless steel the Vitocell 340-M meets the most exacting hygiene requirements. Known for its anti-bacterial properties, it is no coincidence that this metal is also used in the food processing industry, in kitchens and in hospitals. As with every DHW cylinder from Viessmann, the Vitocell 340-M also features all-round high grade thermal insulation to prevent heat losses.

Bi-directional meter for calculating the grid feed-in rate

The most economical option is for the system user himself to consume the power generated on site by the Vitotwin. When the amount of power generated exceeds the domestic demand, excess power is simply exported to the grid. To enable the selling of this electricity, the power supply utility will replace the existing electricity meter with a bi-directional meter [in Germany]. A calibrated electricity meter that measures the total amount of electricity exported is already integrated in the Vitotwin.

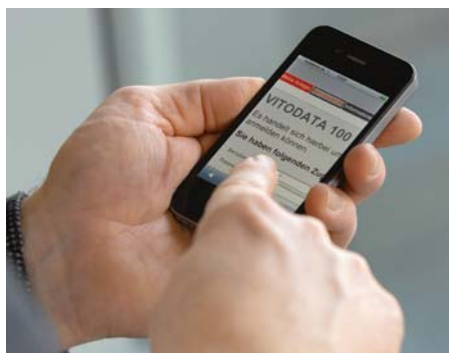

Remote monitoring and control of the micro CHP system via mobile phone network in conjunction with Vitocom 200 and Vitodata 100.

Your heating contractor has everything to hand

Viessmann offers remote monitoring for the Vitotwin, which enables your contractor to check your system. A reassuring feeling, as you can always rely on a trouble-free operation.

Wireless remote control with additional power demand function

To start this function simply press the power demand button. The Vitotwin will generate power until the button is pressed again, or a preset power demand has expired.

Wireless socket function

The automatic power demand function via wireless sockets offers individually tailored on-site consumption of home-generated power. One wireless socket set for the Vitotwin 300-W comprises one transmitter and one receiver socket. The transmitter socket is inserted between the power consumer (e.g. washing machine or dryer) and the mains socket. It transmits a signal to the receiver socket in the micro CHP unit as soon as the selected consumer registers a power flow. This signal triggers the power demand function, and the Stirling engine starts automatically. The intelligent buffer management system separates the power generation from the heat demand of the building. This creates longer runtimes of up to two hours per demand.



Vitocell 340-M combi cylinder



Wireless remote control for the Vitotwin

1 Power demand button



Wireless socket

The company

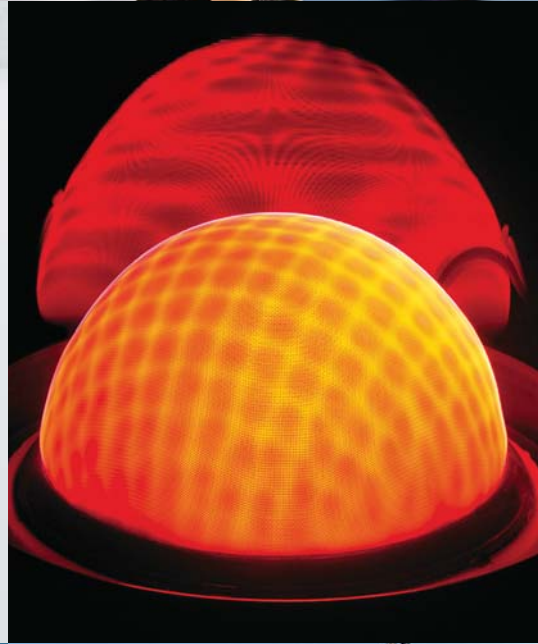

Viessmann – climate of innovation

Viessmann is one of the world's leading manufacturers of intelligent, convenient and efficient systems for heating, cooling and decentralised power generation.

As a third generation family run business, Viessmann has been supplying highly efficient and clean heating systems for many decades.

A strong brand creates trust

Together with our brand label, our key brand message is an identifying feature throughout the world. "Climate of innovation" is a promise on three levels: It is a commitment to a culture of innovation. It is also a promise of enhanced product benefits and, at the same time, an obligation to protect the environment.

Acting in a sustainable manner

For Viessmann, taking responsibility signifies a commitment to acting sustainably.

This means to harmonise ecology, economy and social responsibility so that the needs of

today are met without compromising the quality of life of future generations.

We consider climate protection, environmental responsibility and resource efficiency to be key priorities throughout our company, which has more than 11,400 employees worldwide.

Example of Best Practice

With its strategic sustainability project, Viessmann demonstrates at its own head office in Allendorf (Eder) that the energy and climate policy goals set for 2050 can in fact be achieved today with commercially available technology. The results speak for themselves:

- Expansion of renewables to 60 percent
- CO₂ emissions reduced by 80 per cent

The long-term goal is for the company to sustainably meet all of its own heating energy requirements.



2009/2011/2013:
German Sustainability Award for Production/Brand/Resource Efficiency



Energy Efficiency Award 2010

Viessmann Group

Company details

- Established in: 1917
- Employees: 11,400
- Group turnover: 2.1 billion euros
- Export share: 55 percent
- 27 production companies in 11 countries
- 74 countries with sales companies and representation
- 120 sales offices worldwide

The comprehensive product range from the Viessmann Group for all energy sources and output ranges

- Boilers for oil or gas
- Combined heat and power units
- Heat pumps
- Wood combustion technology
- Biogas production plants
- Biogas upgrading plants
- Solar thermal systems
- Photovoltaics
- Accessories
- Refrigeration technology

По вопросам продаж и поддержки обращайтесь:

Архангельск (8182)63-90-72	Казань (843)206-01-48	Новокузнецк (3843)20-46-81	Смоленск (4812)29-41-54
Астана +7(7172)727-132	Калининград (4012)72-03-81	Новосибирск (383)227-86-73	Сочи (862)225-72-31
Астрахань (8512)99-46-04	Калуга (4842)92-23-67	Омск (3812)21-46-40	Ставрополь (8652)20-65-13
Барнаул (3852)73-04-60	Кемерово (3842)65-04-62	Орел (4862)44-53-42	Сургут (3462)77-98-35
Белгород (4722)40-23-64	Киров (8332)68-02-04	Оренбург (3532)37-68-04	Тверь (4822)63-31-35
Брянск (4832)59-03-52	Краснодар (861)203-40-90	Пенза (8412)22-31-16	Томск (3822)98-41-53
Владивосток (423)249-28-31	Красноярск (391)204-63-61	Пермь (342)205-81-47	Тула (4872)74-02-29
Волгоград (844)278-03-48	Курск (4712)77-13-04	Ростов-на-Дону (863)308-18-15	Тюмень (3452)66-21-18
Вологда (8172)26-41-59	Липецк (4742)52-20-81	Рязань (4912)46-61-64	Ульяновск (8422)24-23-59
Воронеж (473)204-51-73	Магнитогорск (3519)55-03-13	Самара (846)206-03-16	Уфа (347)229-48-12
Екатеринбург (343)384-55-89	Москва (495)268-04-70	Санкт-Петербург (812)309-46-40	Хабаровск (4212)92-98-04
Иваново (4932)77-34-06	Мурманск (8152)59-64-93	Саратов (845)249-38-78	Челябинск (351)202-03-61
Ижевск (3412)26-03-58	Набережные Челны (8552)20-53-41	Севастополь (8692)22-31-93	Череповец (8202)49-02-64
Иркутск (395) 279-98-46	Нижний Новгород (831)429-08-12	Симферополь (3652)67-13-56	Ярославль (4852)69-52-93

Киргизия (996)312-96-26-47

Казахстан (772)734-952-31

Таджикистан (992)427-82-92-69

Эл. почта: vnt@nt-rt.ru || Сайт: <http://vito.nt-rt.ru/>